

**Beam Clamps provide an efficient method for handling wide flange beam sections and plate girders. When lifting, these beam clamps grip the beam at three points, and when properly balanced and safely guided, the beam can be handled even if the clamp is slightly off center lengthwise.**

- Capacities: 4.54 to 31.8 metric tons.
- Eliminates the need for slings, chokers, and spreader bars.
- When applied to load, the tongs automatically open and slide under the flange of the beam.
- Center plate and gripping tongs work together - the heavier the beam, the greater the clamping pressure.
- Model "NS" clamps have a recessed base to accept studs welded to the beam surface.
- Individually Proof Tested to 2 times the Working Load Limit with certification.
- Finish - Red Paint.
- All sizes are **RFID EQUIPPED**.

**NOTE:** Control the beam at all times. Beams should be gripped as near the center as possible. Snubbing lines at each end must be used to control excessive twisting or swinging, and to guide the beam to its proper place. Each lifting situation may have a specific demand which should be addressed before lifting.

### Beam Clamps

Model No.	Working Load Limit (t)*	Flange Grip Range (mm)		Weight Each (kg.)	Dimensions (mm)								
		Width	Thickness		A	B	C	D	E	F	G	H	J
F-5	4.54	102 - 254	13 - 25	31.8	241	660	305	508	648	406	102	254	25.4
F-15	13.6	178 - 432	13 - 51	69.4	394	864	432	686	876	635	178	432	50.8
NS-15	13.6	178 - 432	13 - 51	69.4	394	864	432	686	876	635	178	432	50.8
F-25	25.0	406 - 610	25 - 76	132	584	1219	565	914	1346	946	406	610	76.2
NS-25	25.0	406 - 610	25 - 76	132	584	1219	565	914	1346	946	406	610	76.2
F-35	35.0	406 - 914	41 - 102	235	762	1626	699	1219	1473	1346	406	914	102
NS-35	35.0	406 - 914	41 - 102	235	762	1626	699	1219	1473	1346	406	914	102

\* Maximum Proof Load is 2 times the Working Load Limit and design factor based on EN13155 and ASMEB30.20.

NOTE: : For beam clamps larger than 35 Tons, please contact the Special Engineered Products Department.

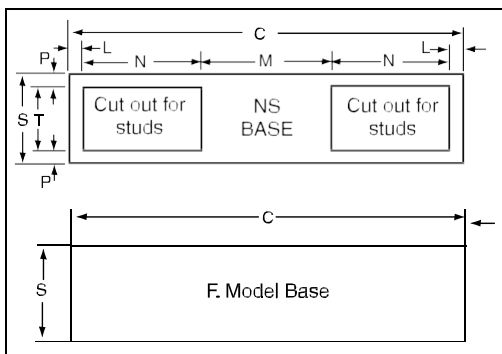
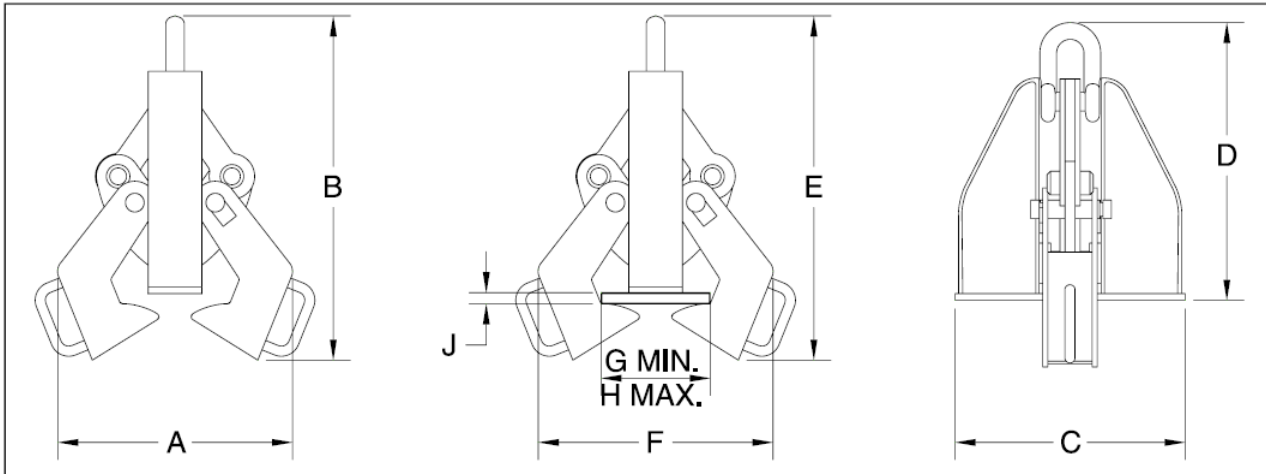

Base Stock No.	Base Dimensions (mm)						
	C	L	M	N	P	S	T
F-5	343	-	-	-	-	76.2	-
F-15	432	-	-	-	-	102	-
NS-15	432	12.7	165	114	19.1	102	63.5
F-25	565	-	-	-	-	140	-
NS-25	565	19.1	197	165	19.1	140	102
F-35	699	-	-	-	-	152	-
NS-35	699	19.1	229	216	19.1	152	114